

This is a "PROVISIONAL BUILDING PLAN" approved only for the purpose of inviting objections from the general public.

Checked and found OK for Public Health (Private) Sign. (Seal) to be submitted to the concerned authority before the start of the work.

Supervisor  
Member  
B.P.A.C.

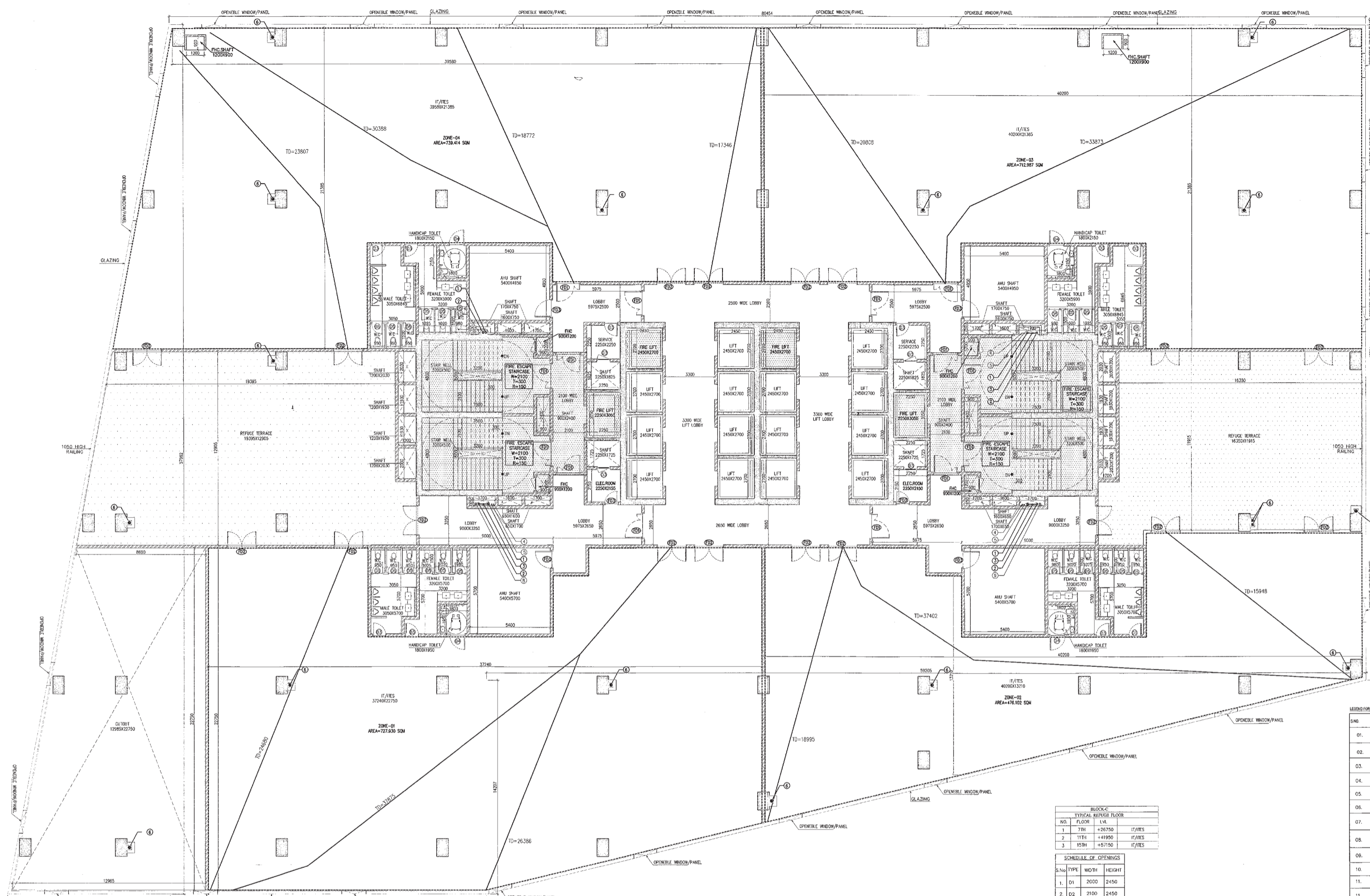

TYPICAL REFUGE FLOOR PLAN  
(7th, 11th, 15th)  
(BLOCK - C)

NOTE: ALL OPENABLE WINDOW / PANEL ARE PROVIDED AT 10M DISTANCE.

LEGEND FOR PLUMBER:

NO.	SYMBOL	DESCRIPTION
01.	①	110 OD SOIL PIPE
02.	②	110 OD WASTE PIPE
03.	③	75 OD ANTI-SIPHONAGE PIPE
04.	④	DWS-DOMESTIC WATER SUPPLY PIPE
05.	⑤	FWS-FLUSHING WATER SUPPLY PIPE
06.	⑥	100 OD TERRACE RAIN WATER PIPE
07.	⑦	110 OD MINTY & BALCONY RAIN WATER PIPE
08.	⑧	DOMESTIC WATER RISER TO O.H. TANK FROM R/WP
09.	⑨	FLUSHING WATER RISER TO O.H. TANK FROM R/WP
10.	⑩	SOFT WATER RISER TO O.H. TANK FROM STP
11.	⑪	110 OD BASEMENT DRAIN PIPE
12.	⑫	FLOOR DRAIN
13.	⑬	FT FLOOR TRAP
14.	⑭	URINAL TRAP
15.	⑮	FLOOR CLEAN OUT
16.	⑯	SOIL PIPE
17.	⑰	WASTE PIPE
18.	⑱	FLUSHING WATER SUPPLY (GRAVITY SUPPLY)
19.	⑲	DOMESTIC WATER SUPPLY (GRAVITY SUPPLY)

BLOCK-C  
TYPICAL REFUGE FLOOR

NO.	FLOOR	LVL.	IT/ITES
1	7th	+28750	IT/ITES
2	11th	+41950	IT/ITES
3	15th	+57150	IT/ITES

SCHEDULE OF OPENINGS

S.NO.	TYPE	WIDTH	HEIGHT
1.	D1	2000	2450
2.	D2	2100	2450
3.	D3	900	2150
4.	D4	1050	2150
5.	D5	750	2150
6.	D1	1200	2450
7.	FD	900	2450
8.	FD1	1700	2450
9.	FD2	2000	2450
9.	FD3	1200	2450

BLOCK-C  
TYPICAL FLOOR PLAN

NO.	FLOOR	LVL.	COMMERCIAL
1	2nd	+17750	COMMERCIAL
2	3rd	+11550	COMMERCIAL
3	4th	+15350	COMMERCIAL
4	5th	+22950	COMMERCIAL/IT/ITES
5	8th	+30050	IT/ITES
6	9th	+34350	IT/ITES
7	10th	+38150	IT/ITES
8	12th	+45750	IT/ITES
10	13th	+49350	IT/ITES
11	14th	+53350	IT/ITES
12	16th	+60050	IT/ITES
13	17th	+64750	IT/ITES

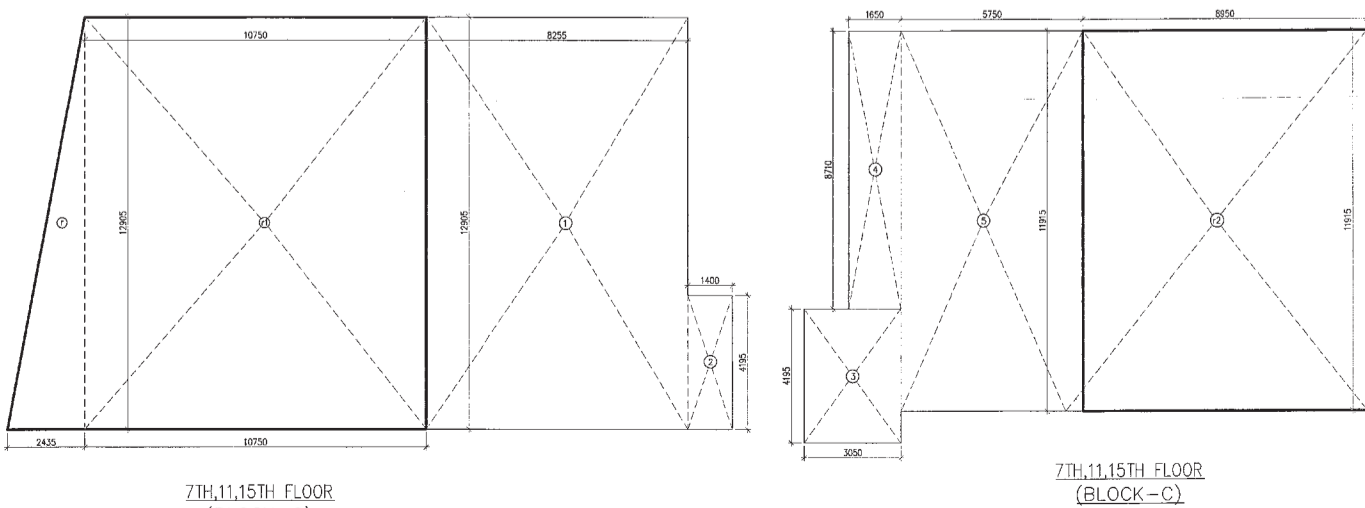

REFUGE AREA CALCULATION (7th, 11th, 15th FLOOR)

NO.	TYPE	WIDTH	HEIGHT	AREA (SQM)
1	D1	2000	2450	4900
2	D2	2100	2450	5145
3	D3	900	2150	1935
4	D4	1050	2150	2265
5	D5	750	2150	1612.5
6	D1	1200	2450	2940
7	FD	900	2450	2205
8	FD1	1700	2450	4165
9	FD2	2000	2450	4900
9	FD3	1200	2450	2940
TOTAL				26100

REFUGE AREA REQUIRED = 26100 SQM

ADDITIONAL SPACE TO ACCOMMODATE WHEEL CHAIR SPACE @ 0.9 SQM PER 200 POPULATION = 3300 SQM

TOTAL REFUGE AREA PROPOSED = 29400 SQM

REFUGE AREA COUNTED IN PLAN = 29400 SQM

Architect  
Hafeez  
Contractor  
29 Bank Street, Borey 401 822, Ind-110070

RISIMS  
ARCHITECTS

RSMS ARCHITECTS PVT. LTD.  
69, Nora Niwas, Bhowani Kunj  
(Behind D2), Vasant Kunj,  
New Delhi-110070.  
Tel.: 011-26898616, 26898617  
www.rsms-arch.com

PROPOSED BUILDING PLANS OF  
BUILDING - B AND REVISED BUILDING PLANS  
OF BUILDING - C, D, E, & F IN CYBER CITY  
UNDER TRANSIT ORIENTED DEVELOPMENT  
(TOD) POLICY FOR MIX LAND USED  
COLONY (70% IT/ITES + 30% COMMERCIAL)  
MEASURING 108.55922 ACRES IN SECTOR 24,  
25 & 25-A, CURUGRAM MANESAR URBAN  
COMPLEX BEING DEVELOPED BY  
DLF CYBER CITY DEVELOPERS LIMITED

OWNER: DLF Cyber City Developers Ltd.  
10th Floor DLF Gateway Tower,  
DLF Cyber City, Gurugram, Haryana  
Pin: 122002

DRAWING TITLE: TYPICAL REFUGE (7TH, 11TH, 15TH) FLOOR PLAN BLOCK-C

REVISION: JOB NO. - DRG NO. BC-04 NORTH -  
SCALE: 1:100 DATE: 01-04-2021

FILE: DEALT BY: CHECKED BY: APPROVED BY:  
ARCHITECT'S SEAL & SIGNATURE OWNER'S SEAL & SIGNATURE